

B VIEW
SCALE 1:1

REV.	ZONE	LTR	DESCRIPTION	DATE	REV/SER	APPD.

- ORDERING INFORMATION
 62E HD S - 3 * * * 0 - * *
 (1) (2) (3) (4) (5) (6) (7) (8) (9) (10)
- 1.SERIES NO.
 62E: DISPLAYPORT ADD HDMI COMBO
 RECEPTACLE DIP TYPE CONNECTOR
- 2.PRODUCT CONSTRUCTION TYPE
 HD:HDMI+DISPLAYPORT
- 3.CONTACT&CONNECTING TYPES:
 S:SOCKET
- 4.COLOR CODES
 3:BLACK
- 5.CONTACT PLATING:
 0:SELECTIVER GOLD FLASH OVER NICKEL
 2:SELECTIVER 15U" GOLD OVER NICKEL
 3:SELECTIVER 30U" GOLD OVER NICKEL
 4:GOLD FLASH ALLOWER OVER NICKEL
- 6.SHELL CONSTRUCTION
 A:SHELL TAIL THROUGH HOLE TYPE WITH RIB
 D:SHELL TAIL THROUGH HOLE TYPE WITHOUT RIB
- 7.SHELL PLATING
 N:SOLDERABLE NICKEL PLATED
 4:GOLD FLASH PLATED
- 8.HOUSING CONSTRUCTION
 1:HOUSING WITHOUT POLES WITHOUT FREEPORT LOGO
 0:HOUSING WITHOUT POLES WITH FREEPORT LOGO
- 9.SUFFIX NO.1
 P:PVC TRAY PACKAGE
 10:SUFFIX NO.2
- 1.HOUSING AND SPACER MATERIALS IS PBT

TABLE A:
B VIEW

ITEM	PART NAME	QTY	MATERIALS	NOTES
⑦	HDMI CONTACT	19	COPPER ALLOY	SELECTIVER Au OVER Ni
⑥	DISPLAYPORT CONTACT	20	COPPER ALLOY	SELECTIVER Au OVER Ni
⑤	BACK SHELL	1	STEEL	Cu UNDER PLATING Ni OVER
④	HDMI SHELL	1	COPPER ALLOY	Cu UNDER PLATING Ni OVER
③	DISPLAYPORT SHELL	1	COPPER ALLOY	Cu UNDER PLATING Ni OVER
②	SPACER	1	THERMOPLASTIC	U.94V-0
①	HOUSING	1	THERMOPLASTIC	U.94V-0

MATERIAL: SEE TABLE A

FINISH:

TOLERANCE UNSPECIFIED:
 .000 ±
 .00 ± 0.15
 .0 ± 0.25
 ANGLE ± 1°

DRAWN: TigerTao 10/15-08
 DESIGNER: TigerTao 10/15-08
 CHECKED: Steven
 APPROVED: Peter

NAME: FREEPORT
 DISPLAYPORT ADD HDMI COMBO
 RECEPTACLE DIP TYPE CONNECTOR
 CUSTOMER DRAWING

SCALE: 3 : 1
 UNIT: mm

DRAWING NO.: R-S162E-1
 REV: 1.0

SHEET: 1 / 2

A3 RS162E11

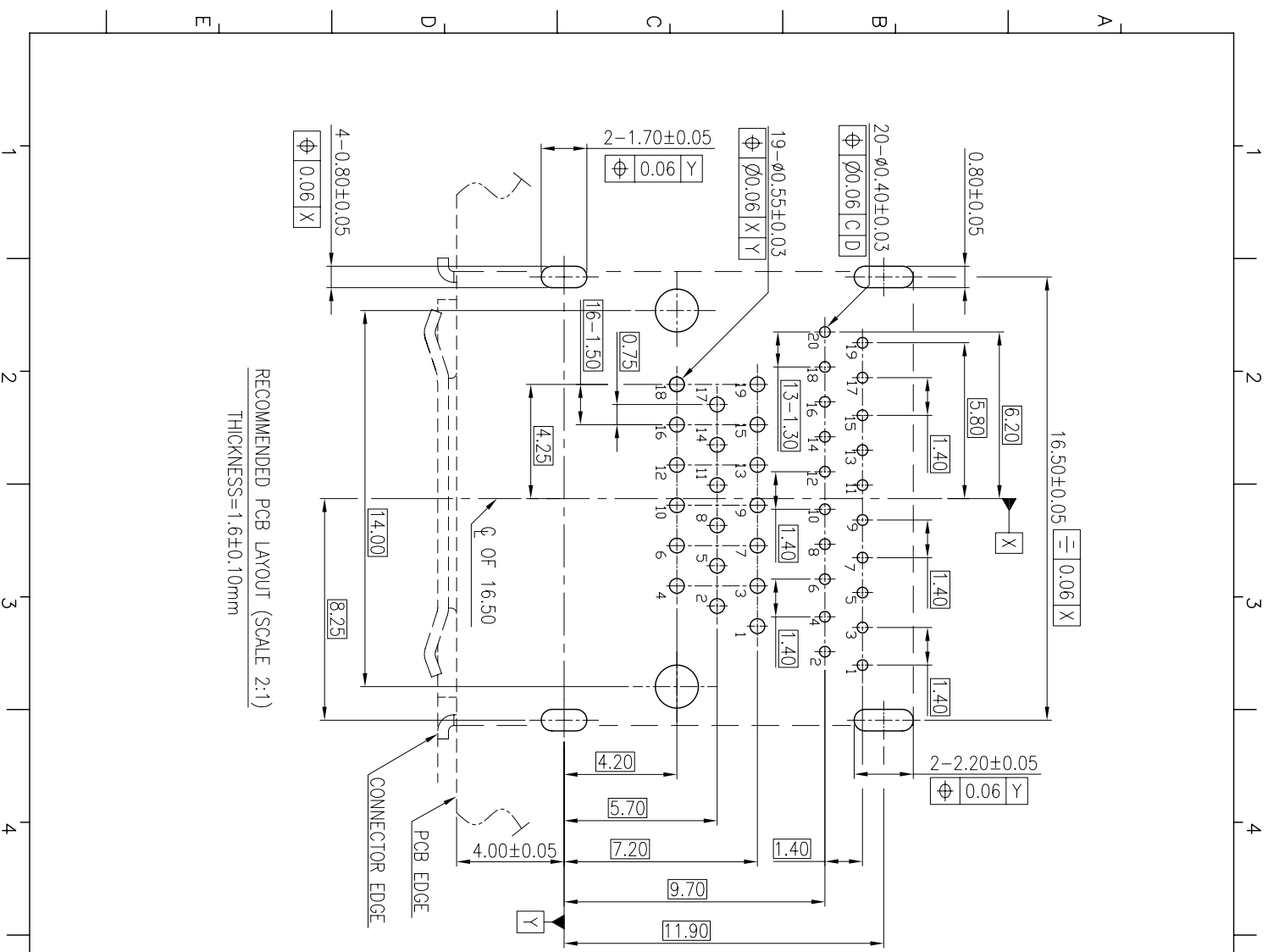

REV.	ZONE	LTR	DESCRIPTION	DATE	REV/SER	APPD.

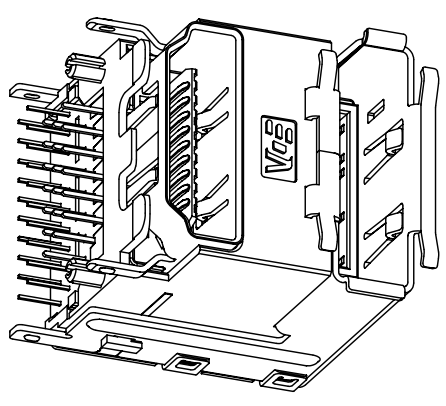

- NOTE:
1. MECHANICAL:
 - 1.1 INSERTION FORCE:
 - 1.1.1 HDMI:44.1N MAX
 - 1.1.2 DISPLAYPORT:44.1MAX
 - 2.1 WITHDRAWAL FORCE:
 - 2.1.1 HDMI:9.8N MIN,39.2N MAX
 - 2.1.2 DISPLAYPORT:9.8N MIN,39.2N MAX
 - 2.ELECTRICAL:
 - 2.1 CONTACT CURRENT RATING:
 - 2.1.1 HDMI:0.5A MAX
 - 2.1.2 DISPLAYPORT:0.5A MAX
 - 2.2 VOLTAGE RATING:
 - 2.2.1 HDMI:40V AC(RMS)
 - 2.2.2 DISPLAYPORT:40V AC(RMS)
 - 2.3 WITHSTANDING VOLTAGE(MATED):
 - 2.3.1 HDMI:300V AC(RMS)
 - 2.3.2 DISPLAYPORT:300V AC(RMS)
 - 2.4 INSULATION RESISTANCE(MATED):
 - 2.4.1 HDMI:150V DC
 - 2.4.2 DISPLAYPORT:150V DC
 3. ENVIRONMENTAL:
 - 3.1 OPERATING TEMPERATURE:
 - 3.1.1 HDMI:-25° TO +85°
 - 3.1.2 DISPLAYPORT:-25° TO +85°

MATERIAL:	FINISH:	TOLERANCE UNSPECIFIED:	 FREEPORT
		.0 0 ± 0.15 .0 0 ± 0.25 ANGLE ± 1°	
RECOMMENDED PCB LAYOUT (SCALE 2:1) THICKNESS=1.6±0.10mm			
DRAWN: Tigertao 10/15-08	DESIGNER: Tigertao 10/15-08	NAME: DISPLAYPORT ADD HDMI COMBO RECEPTACLE DIP TYPE CONNECTOR CUSTOMER DRAWING	SCALE: 3 : 1
CHECKED: Steven	APPROVED: Peter	DRAWING NO.: R-S162E-1	UNIT: mm
		REV: 1.0	SHEET: 2 / 2
			A3 RS162E12