

B VIEW
SCALE 1:1

REV.	ZONE	LTR	DESCRIPTION	DATE	REV/SER	APPD.

ORDERING INFORMATION
 62E HD S - 3 * * * 0 - * *
 (1) (2) (3) (4) (5) (6) (7) (8) (9) (10)
 1.SERIES NO.
 62E: DISPLAYPORT ADD HDMI COMBO
 RECEPTACLE DIP TYPE CONNECTOR
 2.PRODUCT CONSTRUCTION TYPE
 HD:HDMI+DISPLAYPORT
 3.CONTACT&CONNECTING TYPES:
 S:SOCKET
 4.COLOR CODES
 3:BLACK
 5.CONTACT PLATING:
 0:SELECTIVER GOLD FLASH OVER NICKEL
 2:SELECTIVER 15U" GOLD OVER NICKEL
 3:SELECTIVER 30U" GOLD OVER NICKEL
 4:GOLD FLASH ALLOWER OVER NICKEL
 6:SHELL CONSTRUCTION
 A:SHELL TAIL THROUGH HOLE TYPE WITH RIB
 D:SHELL TAIL THROUGH HOLE TYPE WITHOUT RIB
 7.SHELL PLATING
 N:SOLDERABLE NICKEL PLATED
 4:GOLD FLASH PLATED
 8:HOUSING CONSTRUCTION
 1:HOUSING WITHOUT PLOES WITHOUT FREEPORT LOGO
 0:HOUSING WITHOUT PLOES WITH FREEPORT LOGO
 9.SUFFIX NO.1
 P:PVC TRAY PACKAGE
 10.SUFFIX NO.2
 1.HOUSING AND SPACER MATERIALS IS PBT

TABLE A:

ITEM	PART NAME	QTY	MATERIALS	NOTES
⑦	HDMI CONTACT	19	COPPER ALLOY	SELECTIVER Au OVER Ni
⑥	DISPLAYPORT CONTACT	20	COPPER ALLOY	SELECTIVER Au OVER Ni
⑤	BACK SHELL	1	STEEL	Cu UNDER PLATING Ni OVER
④	HDMI SHELL	1	COPPER ALLOY	Cu UNDER PLATING Ni OVER
③	DISPLAYPORT SHELL	1	COPPER ALLOY	Cu UNDER PLATING Ni OVER
②	SPACER	1	THERMOPLASTIC	U.94V-0
①	HOUSING	1	THERMOPLASTIC	U.94V-0

MATERIAL:	SEE TABLE A	TOLERANCE UNSPECIFIED:	± 0.00 ± 0.15 ± 0.25		NAME: DISPLAYPORT ADD HDMI COMBO RECEPTACLE DIP TYPE CONNECTOR CUSTOMER DRAWING	SCALE: 3 : 1	UNIT: mm
FINISH:		ANGLE	± 1°				
DRAWN:	TigerTao	10/15-08					
DESIGNER:	TigerTao	10/15-08					
CHECKED:	Stevenhuong	10/15-08					
APPROVED:	Peterhu	10/15-08					
DRAWING NO.:	R-S162E-1						
REV.:	0.2						

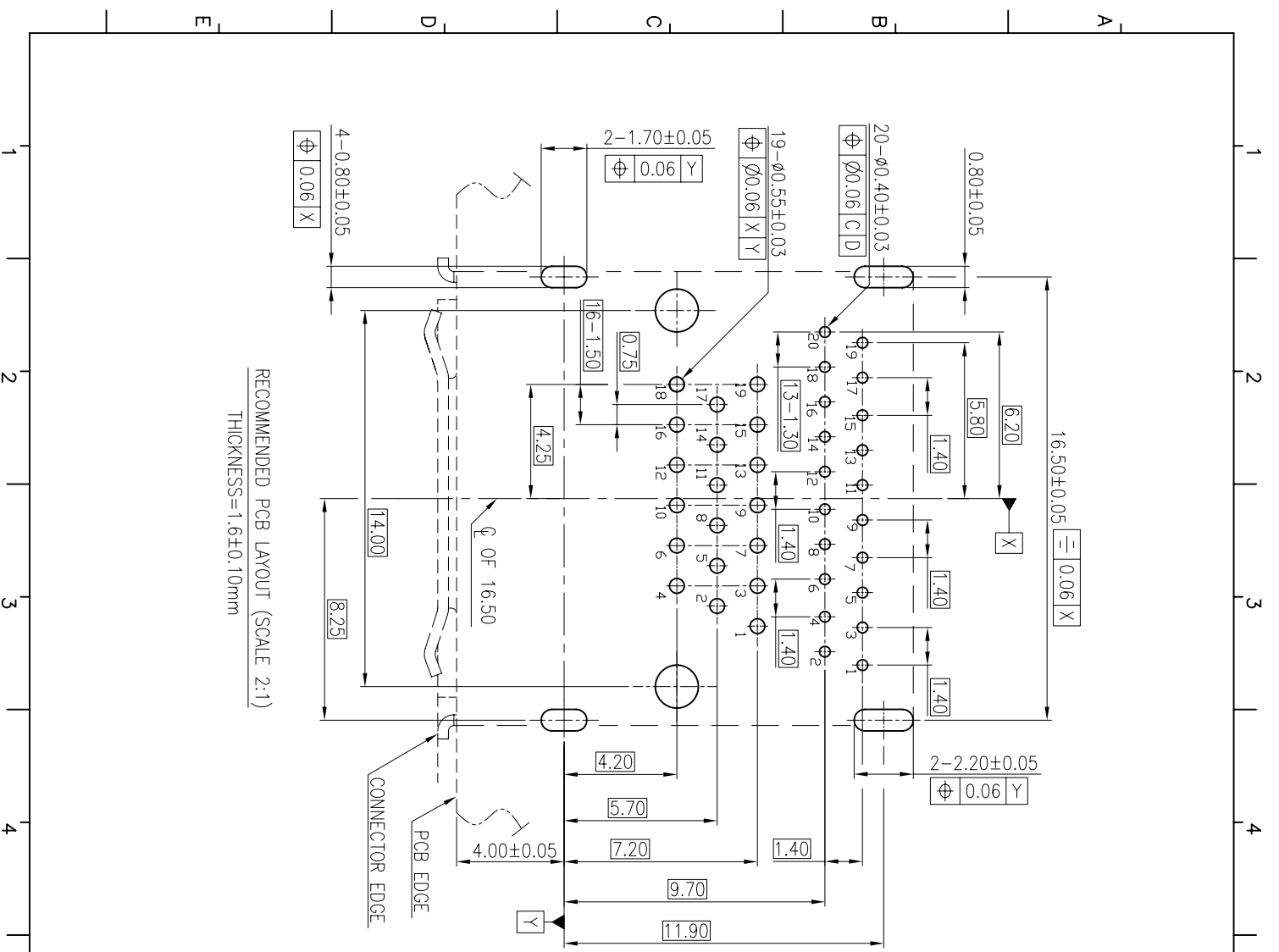

RECOMMENDED PCB LAYOUT (SCALE 2:1)
THICKNESS=1.6±0.10mm

REV.	ZONE	LTR	DESCRIPTION	DATE	REVISER	APPD.

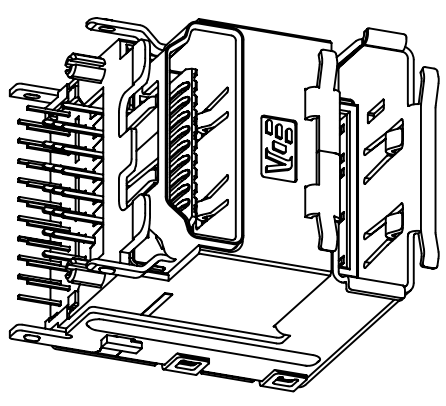

NOTE:

1. MECHANICAL:
 - 1.1 INSERTION FORCE:
 - 1.1.1 HDMI:44.1N MAX
 - 1.1.2 DISPLAYPORT:44.1MAX
 - 2.1 WITHDRAWAL FORCE:
 - 2.1.1 HDMI:9.8N MIN,39.2N MAX
 - 2.1.2 DISPLAYPORT:9.8N MIN,39.2N MAX
 - 2.ELECTRICAL:
 - 2.1 CONTACT CURRENT RATING:
 - 2.1.1 HDMI:0.5A MAX
 - 2.1.2 DISPLAYPORT:0.5A MAX
 - 2.2 VOLTAGE RATING:
 - 2.2.1 HDMI:40V AC(RMS)
 - 2.2.2 DISPLAYPORT:40V AC(RMS)
 - 2.3 WITHSTANDING VOLTAGE(MATED):
 - 2.3.1 HDMI:300V AC(RMS)
 - 2.3.2 DISPLAYPORT:300V AC(RMS)
 - 2.4 INSULATION RESISTANCE(MATED):
 - 2.4.1 HDMI:150V DC
 - 2.4.2 DISPLAYPORT:150V DC
 3. ENVIRONMENTAL:
 - 3.1 OPERATING TEMPERATURE:
 - 3.1.1 HDMI:-25° TO +85°
 - 3.1.2 DISPLAYPORT:-25° TO +85°

MATERIAL:		FINISH:	
TOLERANCE UNSPECIFIED:		DRAWN: Tigertao 10/15-08	
∅ 0.0	± 0.15	DESIGNER: Tigertao 10/15-08	NAME: DISPLAYPORT ADD HDMI COMBO
∅ 0	± 0.25	CHECKED: Stevenhuang 10/15-08	RECEPTACLE DIP TYPE CONNECTOR
ANGLE	± 1°	APPROVED: Peterfu 10/15-08	CUSTOMER DRAWING
SCALE: 3 : 1		DRAWING NO.: R-S162E-1	
UNIT: mm		SHEET: 2 / 2	
		REV: 0.2	

1 2 3 4 5 6 7 8

A B C D E