

REV	ZONE	LTR	DESCRIPTION	DATE	REVISER	APPD
2	E8	▲	變更LAYOUT圖位置	10/16-07	Freeqin	

A
B
C
D
E
F

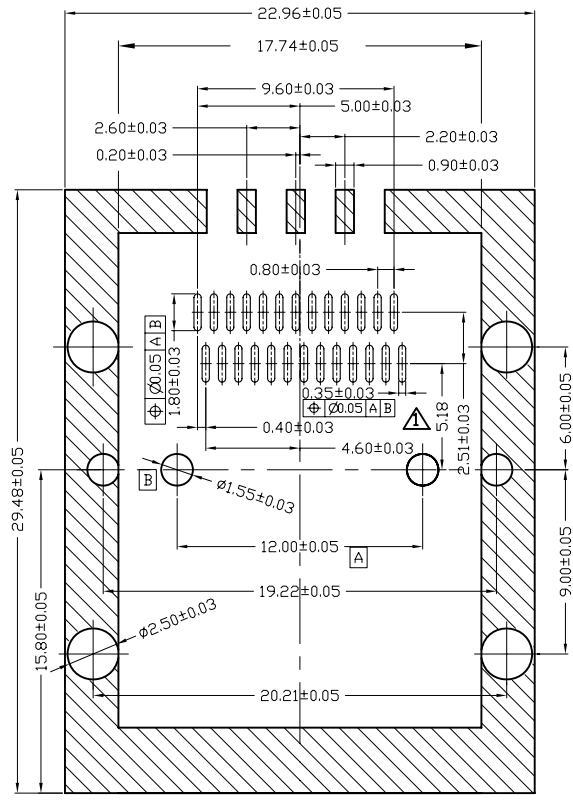

RECOMMENDED PCB LAYOUT

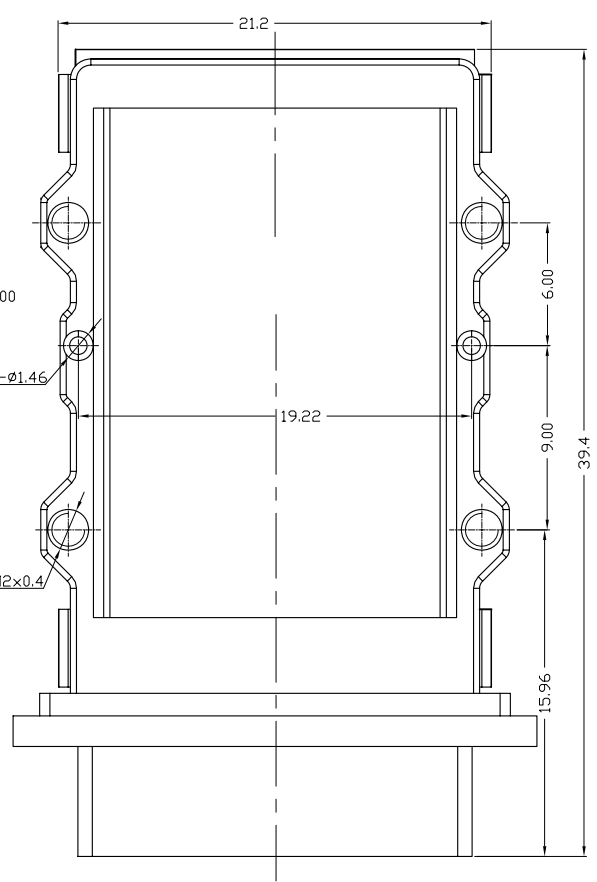
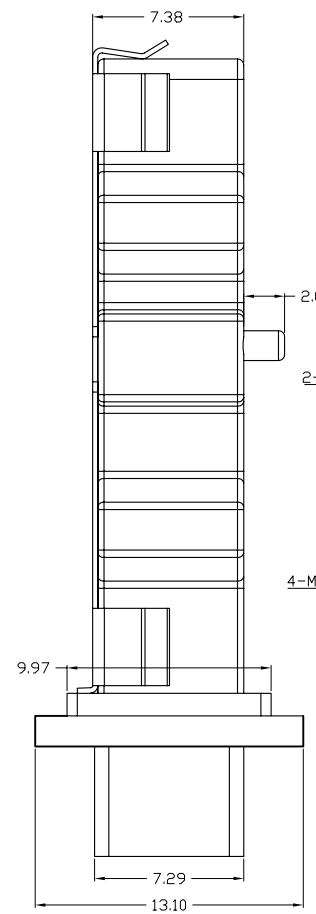
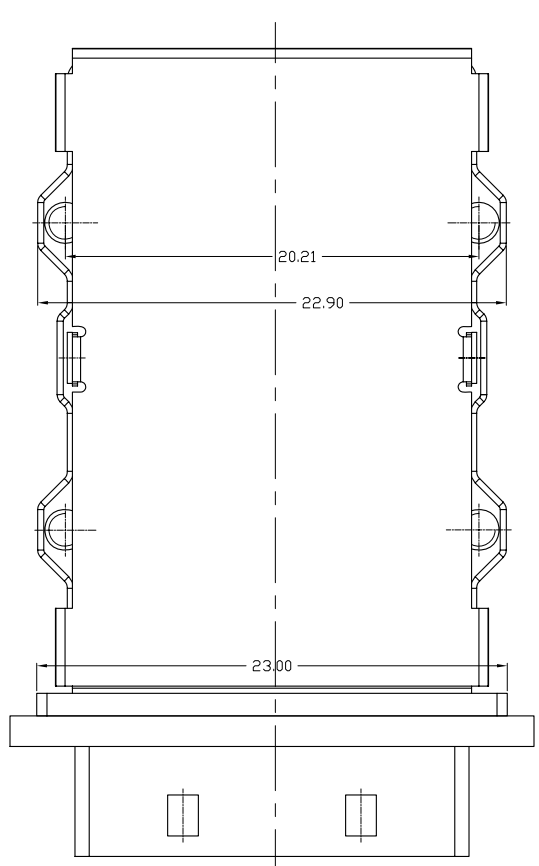
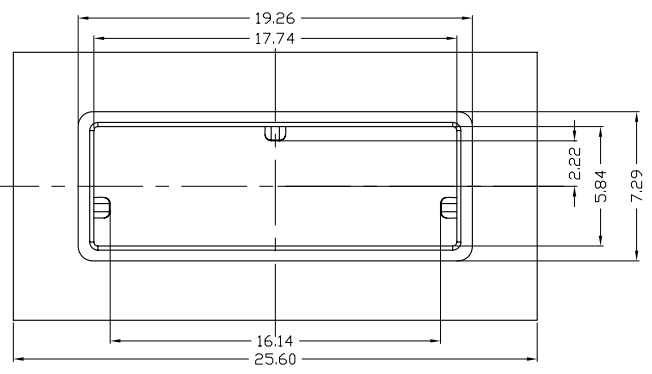

REMARKS:
1. THE ▼ MARKED DIMENSION IS IMPORTANT AND SHOULD BE CONTROLLED BY QC

MATERIAL	TOLERANCE UNSPECIFIED
	±
	±0.20
	±0.25
ANGLE	± 1°
FINISH	
DRAWN	YINYIXIN 07/03/07
DESIGNER	YINYIXIN 07/03/07
CHECKED	DAVID 10/16/07
APPROVED	PETERHU 10/16/07

PAPT NO.	61H026-S1N	
SCALE	1:1	UNIT mm
NAME	MINI SAS RECEPTACLE 26pin SMT TYPE HOOD	SHEET 2/2
DRAWING NO.	R-S161U-0	REV 2
A4	RS161U02	

1 2 3 4 5 6 7 8